

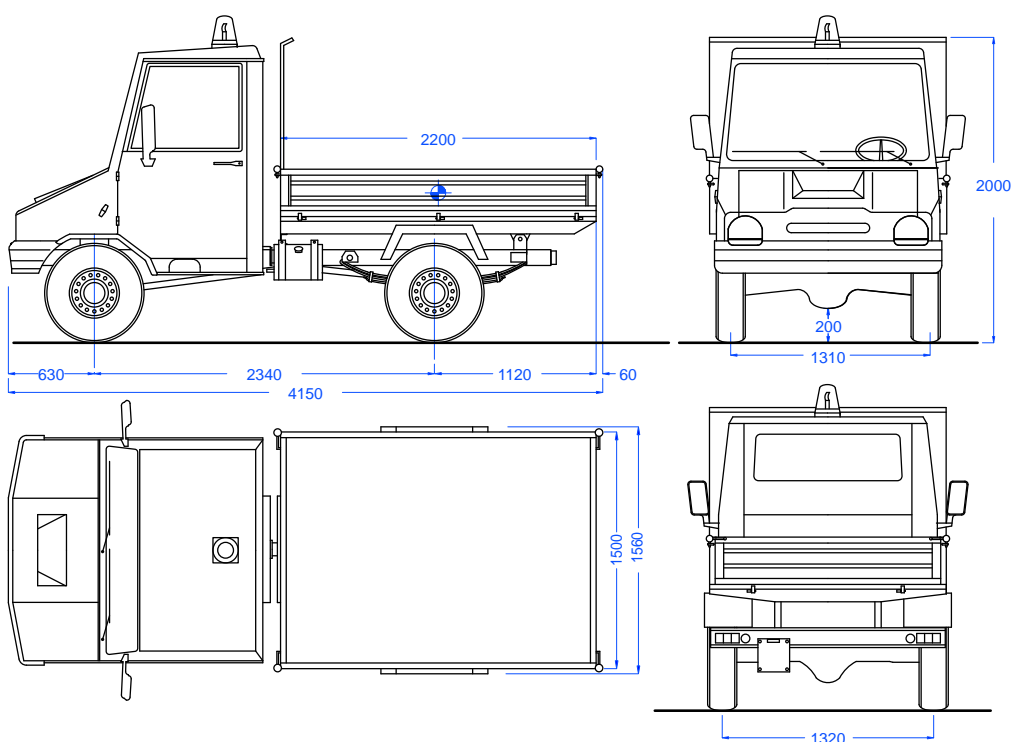

## TECHNICAL SPECIFICATIONS

<b>DRIVER POSITION</b>	Left-hand drive.
<b>GEARBOX</b>	10 forward + 2 reverse speeds (5+1 low range, 5+1 high range) with independent disengagement of the front-wheel drive (in both low and high range).
<b>BRAKES</b>	<u>Servo-assisted hydraulic brakes</u> with dual-circuit pump, rear drums and front discs. Mechanical parking brake on rear axle.
<b>WHEELS/TYRES</b>	195R14C. (Optional remoulded 195/70 R15C off-road tyres, <u>not covered by warranty</u> ).
<b>CAB</b>	Type-approved 2 seats, sound-insulated with tempered glass, 2 windscreen wipers, storage compartment under tilting bench seat, interior heating (not available with air-cooled engines), seat-belts, wind-down windows, type-approved crush protection roll-bar.
<b>BODY</b>	2200 x 1500 x 300 mm with headboard (behind cab).
<b>PAYLOAD</b>	1500 kg (2900 kg gross vehicle weight rating).
<b>CHASSIS</b>	Tubular profiles and sheet steel with central joint on tapered roller bearings for enhanced grip of the 4 driven wheels on any type of terrain.
<b>SUSPENSION</b>	Front: MacPherson independent suspension with coil springs and shock-absorbers with top mounting equipped with ball bearing. Rear: with leaf-springs and double-acting shock absorbers.
<b>POWER TAKE-OFF</b>	Predisposed, variable-speed central coupling (on transfer case).
<b>ELECTRICAL SYSTEM</b>	12V regulation-compliant lighting system, reversing light, flashing beacon.
<b>SPEED</b>	40.0 km/h.
<b>STANDARD EQUIPMENT</b>	Spare wheel, tow bar (non-type approved), rear light guards, wash/wipe kit, combination light switch, jack with wrench, user accessories, use and maintenance manual, colour: red.

# RAMBO S2000



## VERSIONS

	PART NUMBER	DESCRIPTION
<b>L1</b>	E03 P00A	<b>Lombardini 9LD625/2</b> twin-cylinder, 4-stroke, air-cooled diesel. Rated power 26.0 HP (18.8 kW) @ 3000 rpm. Displacement 1248 cc, peak torque 67 Nm @ 2000 rpm.
<b>LDW</b>	E03 P00C	<b>Lombardini LDW 1404</b> (97/68/EC Step III A Approved), 4-cylinder, 4-stroke, water-cooled diesel with axial fan. Rated power 35.0 HP (25.5 kW) @ 3600 rpm, displacement 1371 cc, peak torque 78 Nm @ 2200 rpm.

## OPTIONAL VARIANTS AND ACCESSORIES

PART NUMBER	DESCRIPTION
E03 P001	Electro-hydraulic rear tipping with 2 pistons
E03 P002	Electro-hydraulic three-way tipping with 2 pistons ( <b>only for version without central joint</b> )
E03 P006	PTO unit with disengagement, drive shaft and manual accelerator
E03 P007	Tow bar, type-approved for trailer weight of 1400 kg
E03 P008	Power-assisted steering
E03 P009	195/70 R15C tyres (difference)
E03 P012	Stereo radio system
E03 P016	Cab-mounted work-light bar with 2 lights
E03 G019	Inverter unit for rear PTO
Colour	Colours other than the standard red to be chosen from the catalogue (difference)
<b>VARIANTS AND ACCESSORIES FOR PICK-UP BODY: SEE SECTION 4</b>	